

TT PRO 200



Inline mixed-flow fans

- Maximum airflow: 1040
- Sound pressure level LpA at 3 m: 45
- Motor type: AC
- Impeller type: Mixed
- Casing material: Plastic
- Installation in any position

	Unit of measurement	TT PRO 200	
Connected air duct size	mm	200	
Speed	-	2	
Minimum supply voltage	V	230	
Maximum supply voltage	V	230	
Power supply frequency	Hz	50/60	
Rated power	W	76	108
Unit current	A	0.34	0.48
Maximum airflow	m ³ /h	830	1040
Sound pressure level LpA at 3 m	dB(A)	39	45
Weight	kg	3.95	
Transported air temperature (max)	°C	60	
Ingress protection rating	-	IPX4	
Ingress protection rating of the drive	-	IPX4	

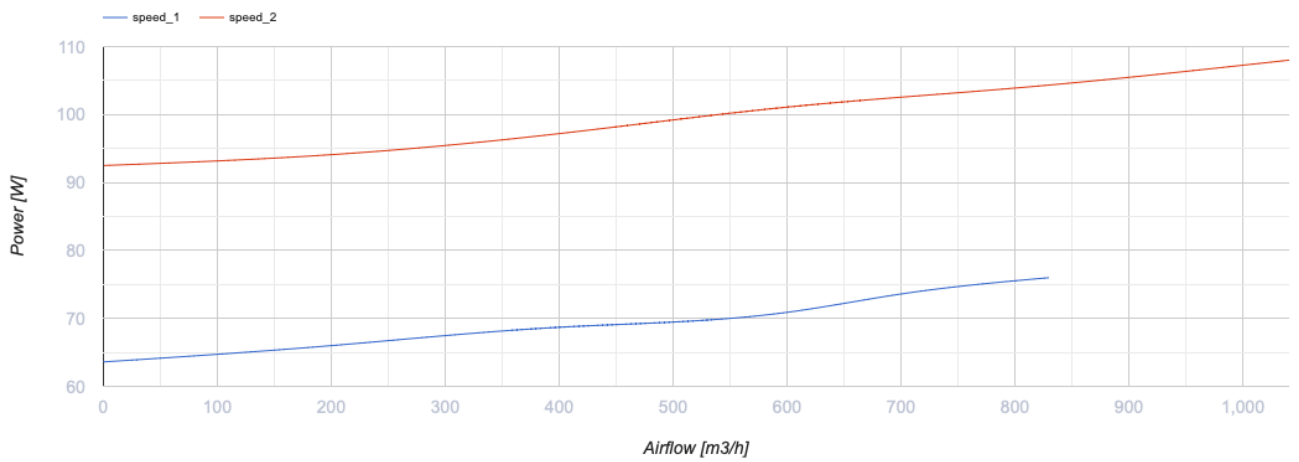
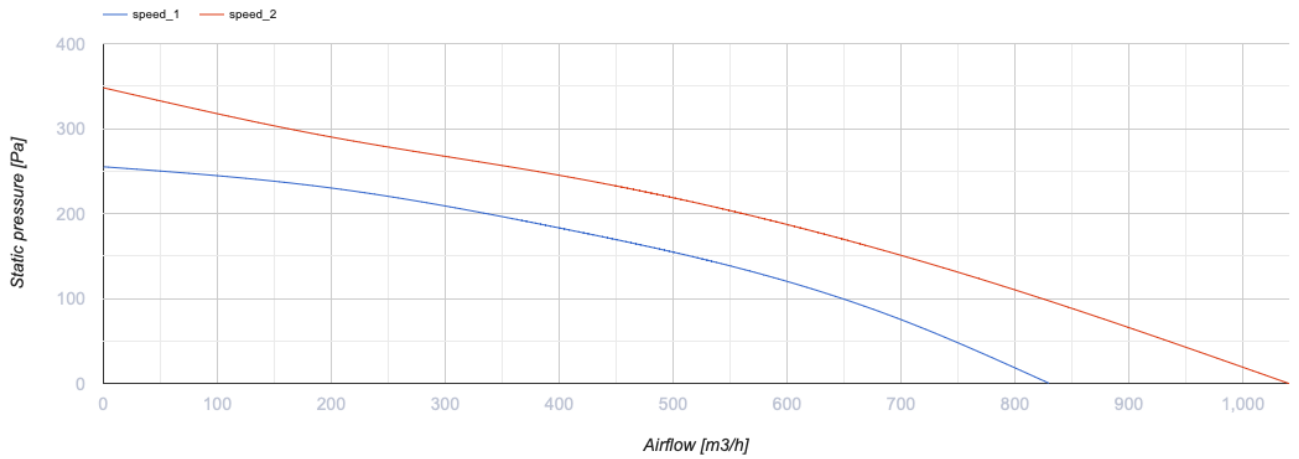

Dimensions

ØD	B	H	L
199	239	261	295.5

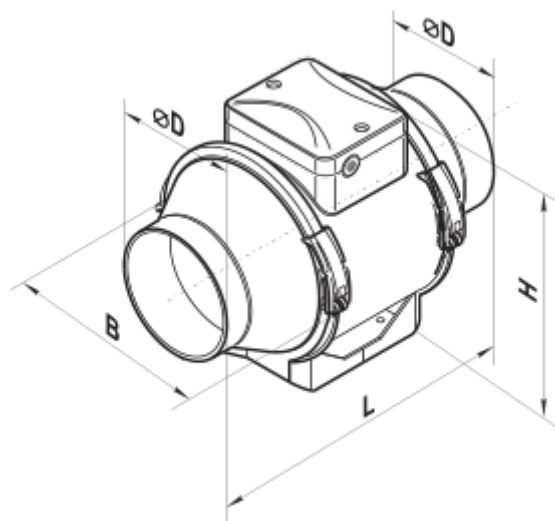

Ecodesign

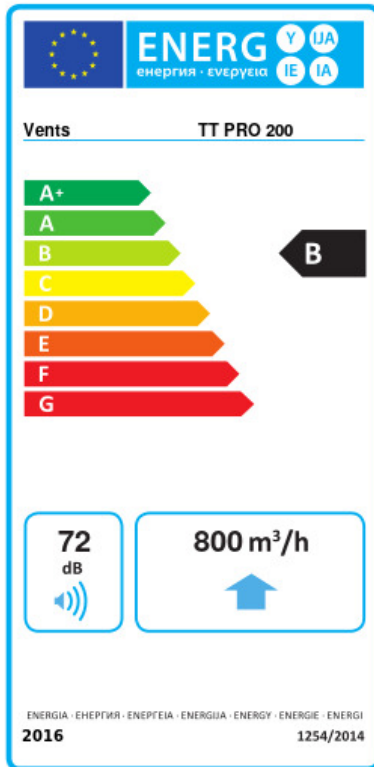

Trademark	Vents					
Model	TT PRO 200					
Specific energy consumption (SEC) (kWh/(m ² /a))	Cold		Average		Warm	
	53.6	A+	26.5	B	11	E
Type of ventilation unit	Unidirectional					
Type of drive installed	Variable speed					
Type of heat recovery system	None					
Maximum flow rate (m ³ /h)	800					
Electric power input (W)	108					
Reference flow rate (m ³ /s)	0.156					
Reference pressure difference (Pa)	50					
Specific power input (SPI) (W/(m ³ /h))	0.136					
Control typology	Local demand control					
Maximum external leakage rates (%)	2.7					
Declared typology	RVU UVU					
Sound power level (dB(A))	72					
The annual electricity consumption (AEC) (kWh/a)	Cold		Average		Warm	
	72		72		72	
The annual heating saved (AHS) (kWh/a)	Cold		Average		Warm	
	5536		2830		1280	