

# TT 150



Inline mixed-flow fans

- Maximum airflow: 502
- Sound pressure level LpA at 3 m: 44
- Motor type: AC
- Impeller type: Mixed
- Casing material: Plastic
- Installation in any position

	Unit of measurement	TT 150	
Connected air duct size	mm	150	
Speed	-	2	
Minimum supply voltage	V	230	
Maximum supply voltage	V	230	
Power supply frequency	Hz	50/60	
Rated power	W	47	60
Unit current	A	0.21	0.27
Maximum airflow	m <sup>3</sup> /h	405	502
Sound pressure level LpA at 3 m	dB(A)	33	44
Weight	kg	3.19	
Transported air temperature (max)	°C	60	
Transported air temperature (min)	°C	-25	
Ingress protection rating	-	IPX4	
Ingress protection rating of the drive	-	IPX4	

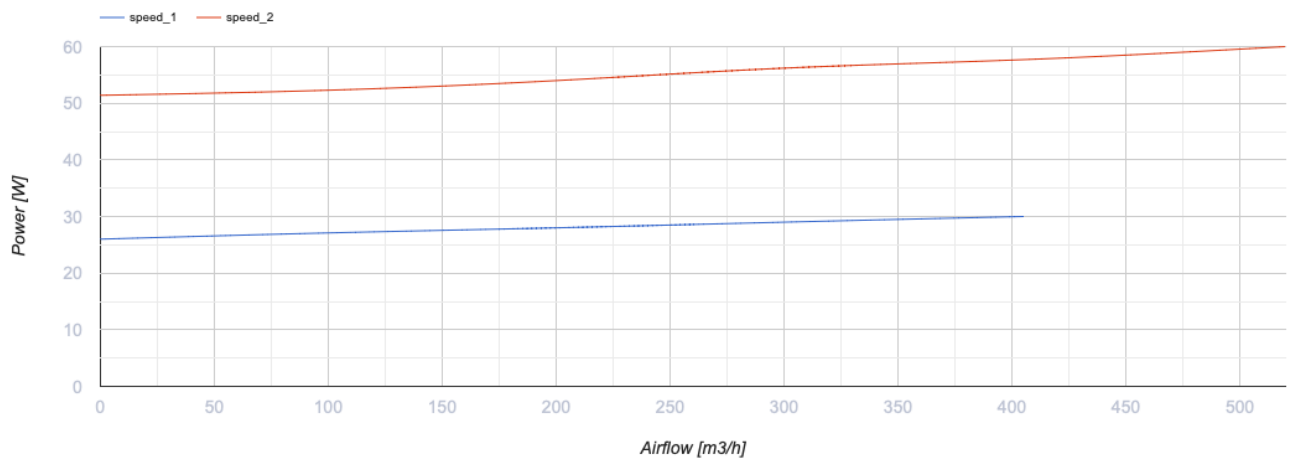
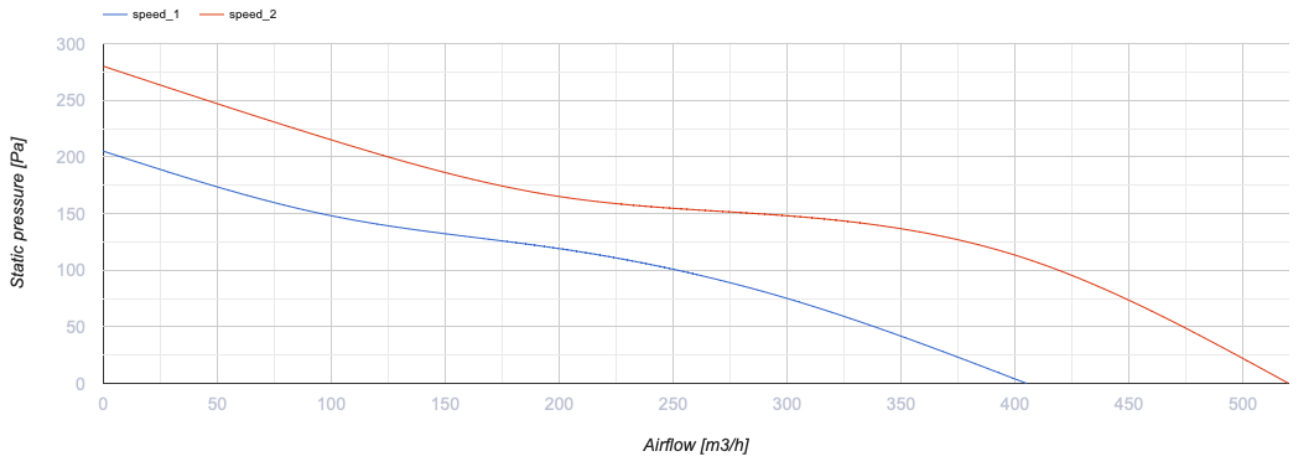

## Dimensions

ØD	B	H	L
146	223	250	295

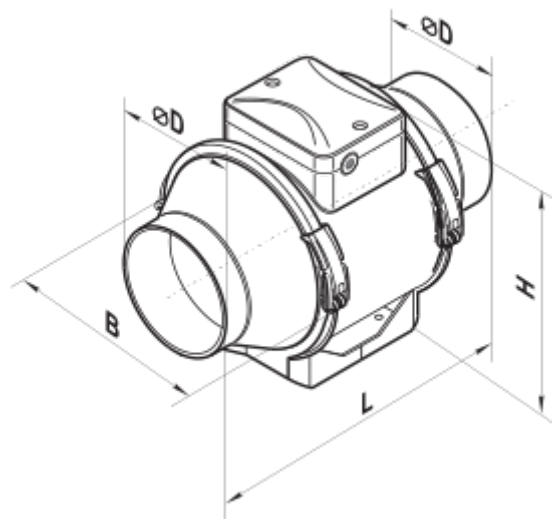

## Ecodesign

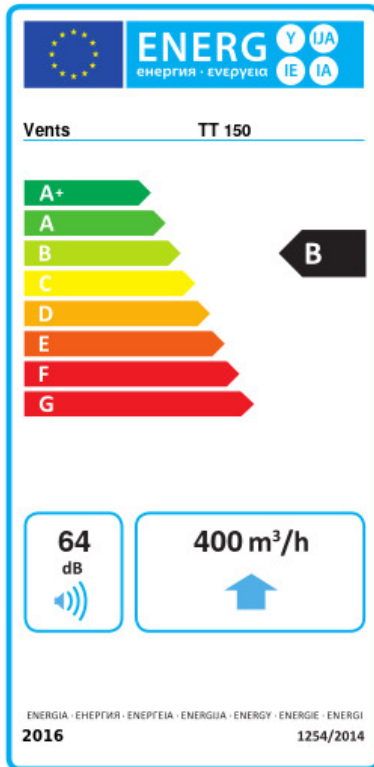

Trademark	Vents					
Model	TT 150					
Specific energy consumption (SEC) (kWh/(m <sup>2</sup> /a))	Cold		Average		Warm	
	53.9	A+	26.8	B	11.3	E
Type of ventilation unit	Unidirectional					
Type of drive installed	Variable speed					
Type of heat recovery system	None					
Maximum flow rate (m <sup>3</sup> /h)	400					
Electric power input (W)	60					
Reference flow rate (m <sup>3</sup> /s)	0.086					
Reference pressure difference (Pa)	50					
Specific power input (SPI) (W/(m <sup>3</sup> /h))	0.113					
Control typology	Local demand control					
Maximum external leakage rates (%)	2.7					
Declared typology	RVU UVU					
Sound power level (dB(A))	64					
The annual electricity consumption (AEC) (kWh/a)	Cold		Average		Warm	
	60		60		60	
The annual heating saved (AHS) (kWh/a)	Cold		Average		Warm	
	5536		2830		1280	