

# TT 100



## Inline mixed-flow fans

- Maximum airflow: 187
- Sound pressure level LpA at 3 m: 36
- Motor type: AC
- Impeller type: Mixed
- Casing material: Plastic
- Installation in any position

	Unit of measurement	TT 100	
Connected air duct size	mm	100	
Speed	-	2	
Minimum supply voltage	V	230	
Maximum supply voltage	V	230	
Power supply frequency	Hz	50/60	
Rated power	W	21	33
Unit current	A	0.11	0.21
Maximum airflow	m <sup>3</sup> /h	145	187
Sound pressure level LpA at 3 m	dB(A)	27	36
Weight	kg	1.45	
Transported air temperature (max)	°C	40	
Transported air temperature (min)	°C	-25	
Ingress protection rating	-	IPX4	
Ingress protection rating of the drive	-	IPX4	

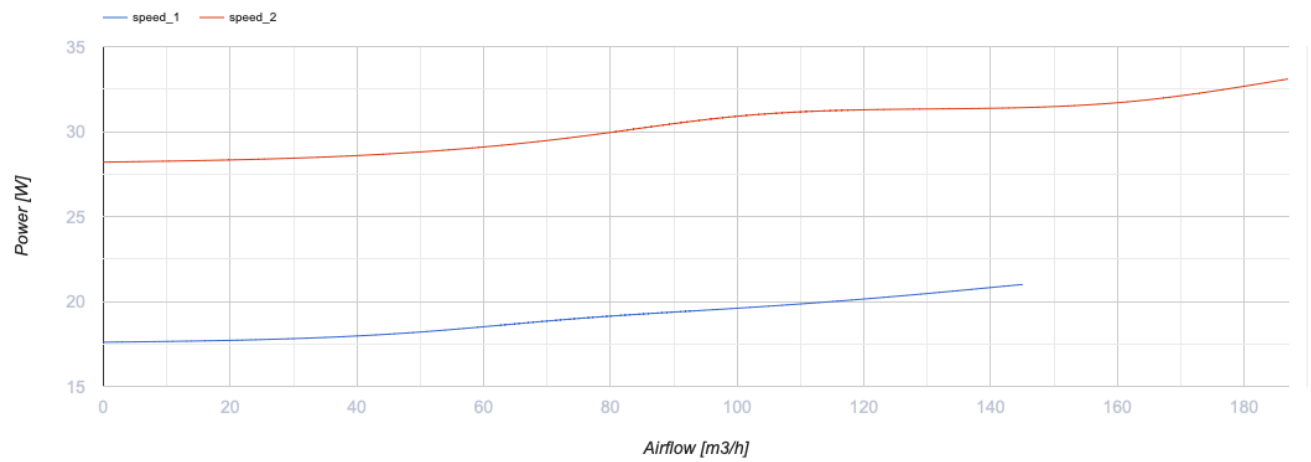
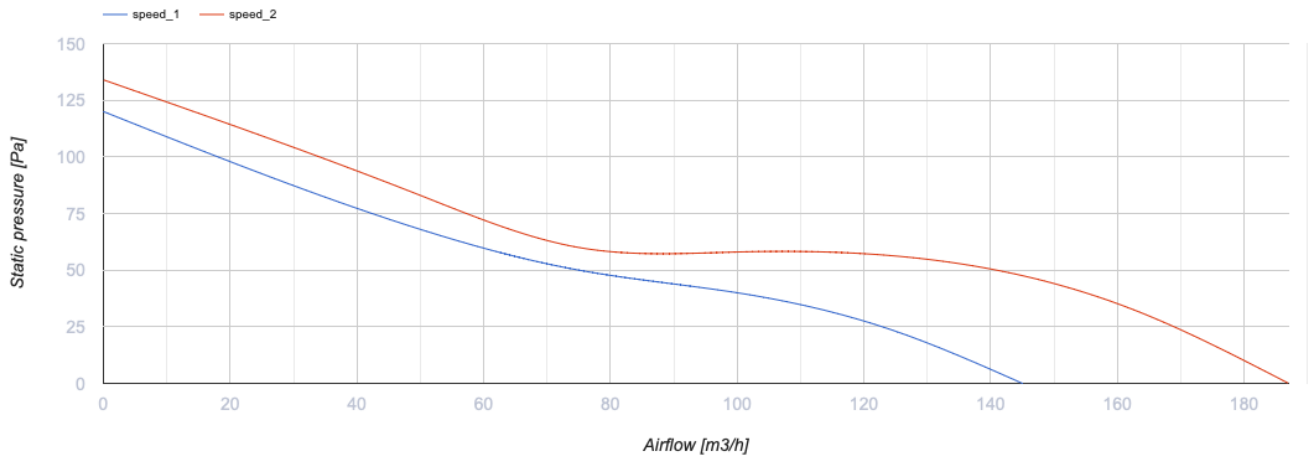

## Dimensions

ØD	B	H	L
96	167	190	246

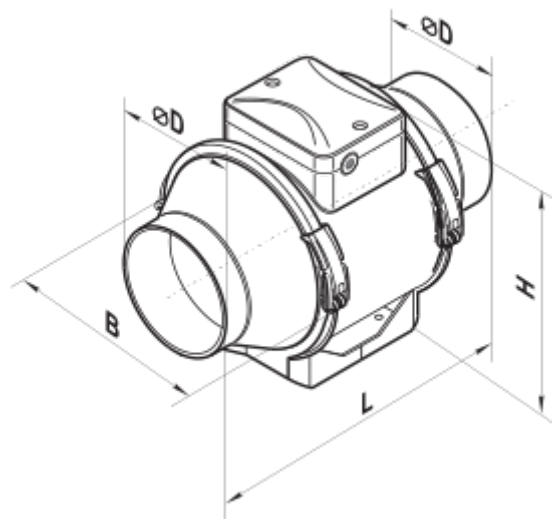

## Ecodesign

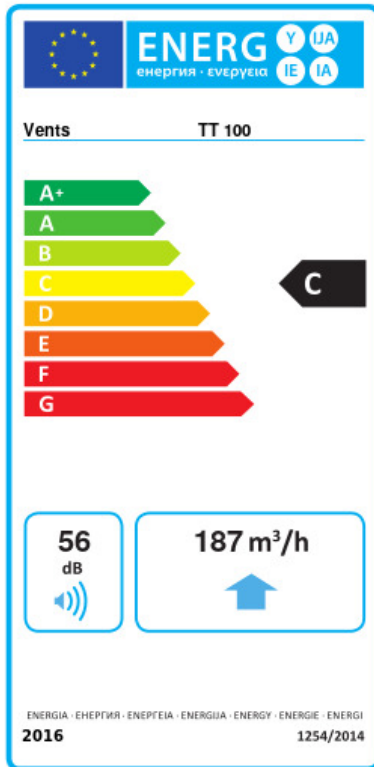

Trademark	Vents					
Model	TT 100					
Specific energy consumption (SEC) (kWh/(m <sup>2</sup> /a))	Cold		Average		Warm	
	49.5	A+	24.4	C	10.1	E
Type of ventilation unit	Unidirectional					
Type of drive installed	Variable speed					
Type of heat recovery system	None					
Maximum flow rate (m <sup>3</sup> /h)	187					
Electric power input (W)	33					
Reference flow rate (m <sup>3</sup> /s)	0.036					
Specific power input (SPI) (W/(m <sup>3</sup> /h))	0.123					
Control typology	Local demand control					
Maximum external leakage rates (%)	2.7					
Declared typology	RVU UVU					
Sound power level (dB(A))	56					
The annual electricity consumption (AEC) (kWh/a)	Cold		Average		Warm	
	72		72		72	
The annual heating saved (AHS) (kWh/a)	Cold		Average		Warm	
	5131		2623		1186	